



Robot Cop

ROBORISE-IT!

ROBOTIC EDUCATION



PRIME



69

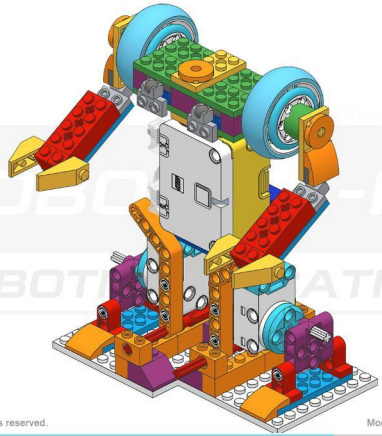
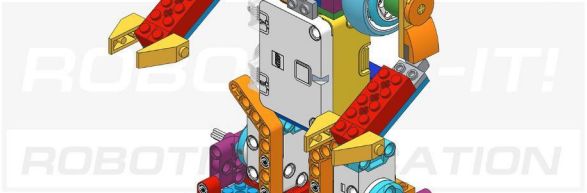

22/34

0

91



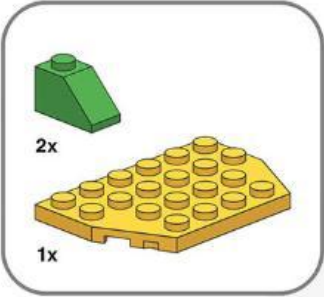
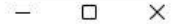

70

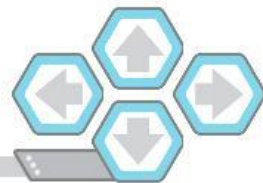
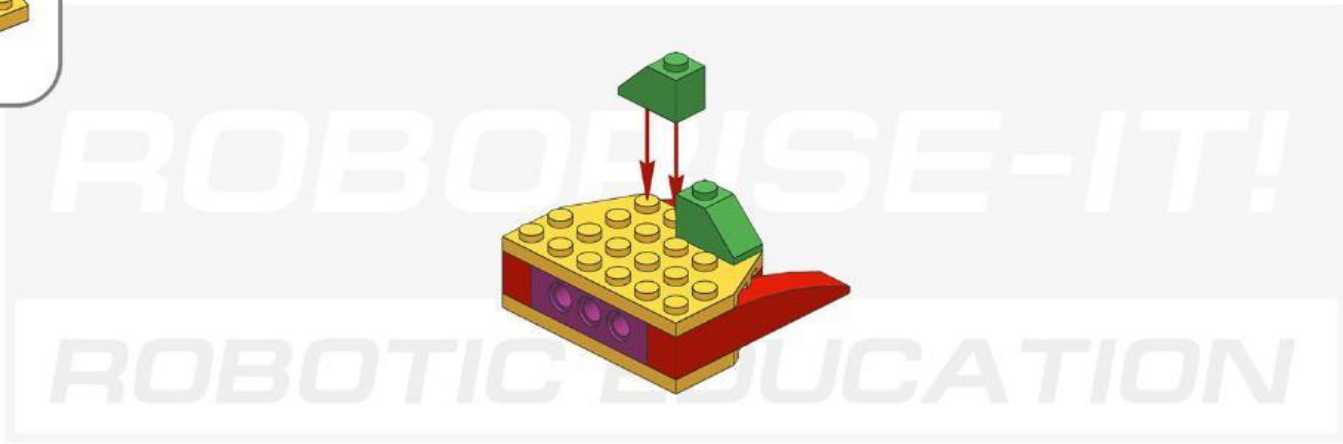

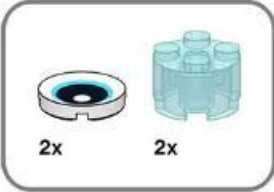

ROBORISE-IT!
ROBOTIC EDUCATION

71

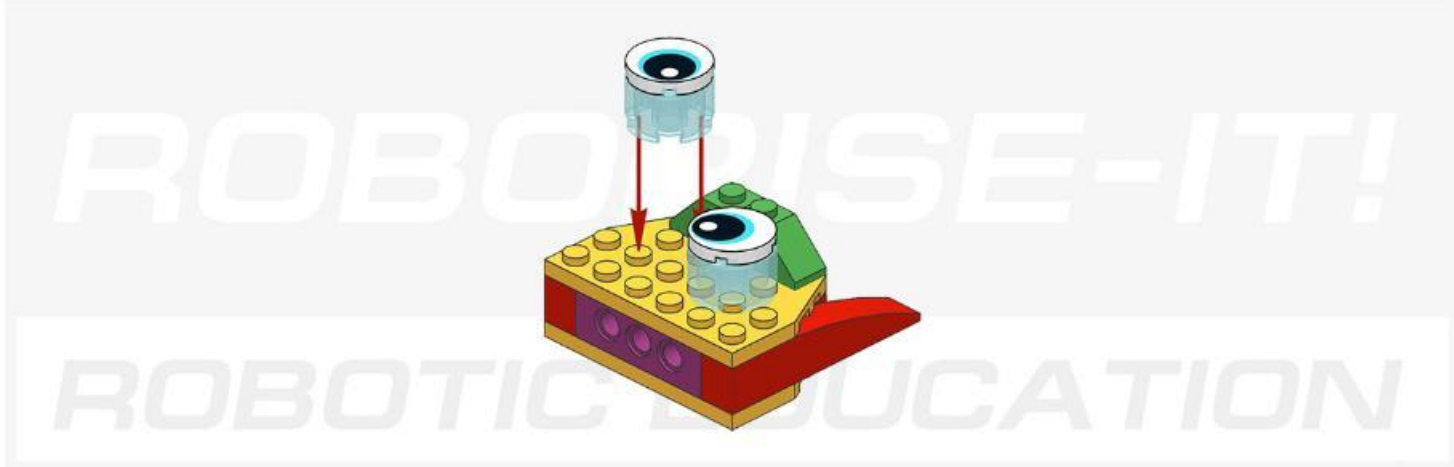

24/34

0

93



©2021 roboriseit.com. All rights reserved.

Model by Ignat Khlebnikov

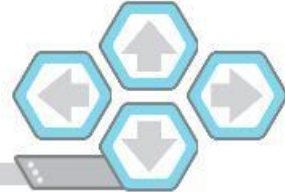

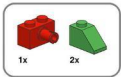

ROBORISE-IT!
ROBOTIC EDUCATION

72



25/34

0

94



©2021 roboriseit.com. All rights reserved.

Model by Ignat Khliebikov



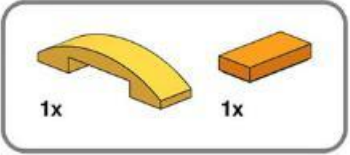

ROBORISE-IT!
ROBOTIC EDUCATION

73



26/34

0

95



©2021 roboriseit.com. All rights reserved.

Model by Ignat Khlebnikov

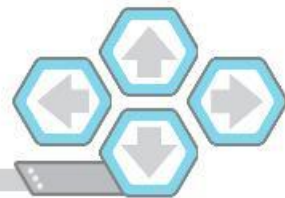



74

ROBORISE-IT!
ROBOTIC EDUCATION



27/34



96



©2021 roboriseit.com. All rights reserved.

Model by Ignat Khliebikov





75

ROBORISE-IT!
ROBOTIC EDUCATION

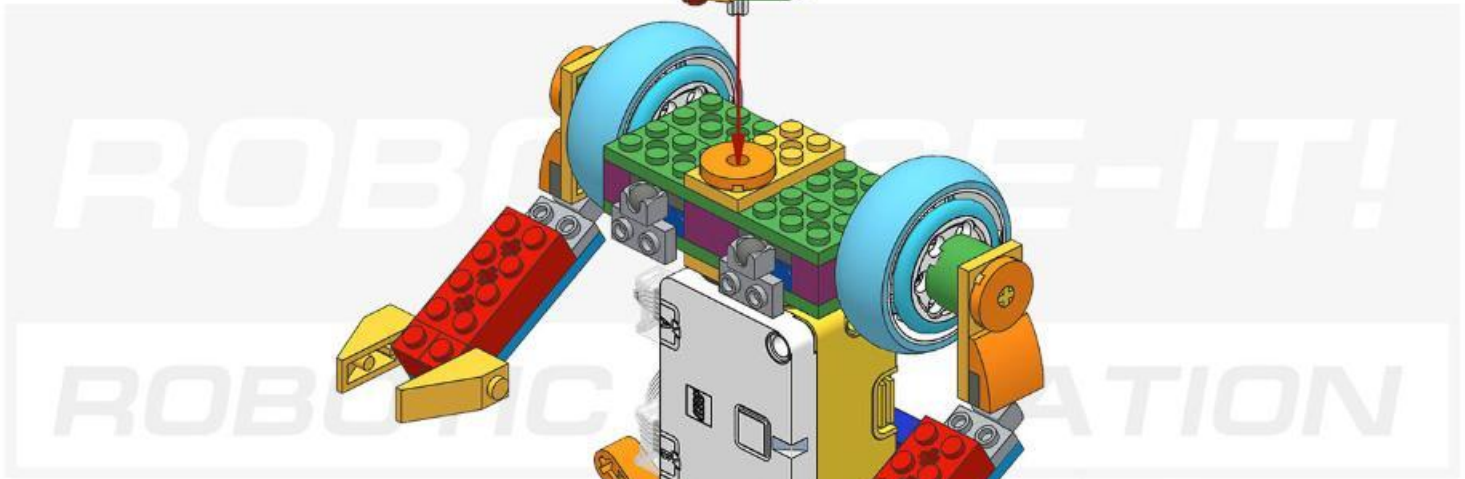

28/34

0

97



©2021 roboriseit.com. All rights reserved.

Model by Ignat Khlebnikov

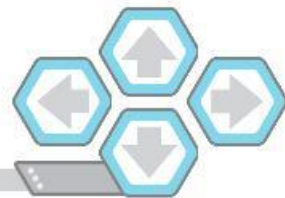



76

ROBORISE-IT!
ROBOTIC EDUCATION

ROBORISE-IT!
ROBOTIC EDUCATION

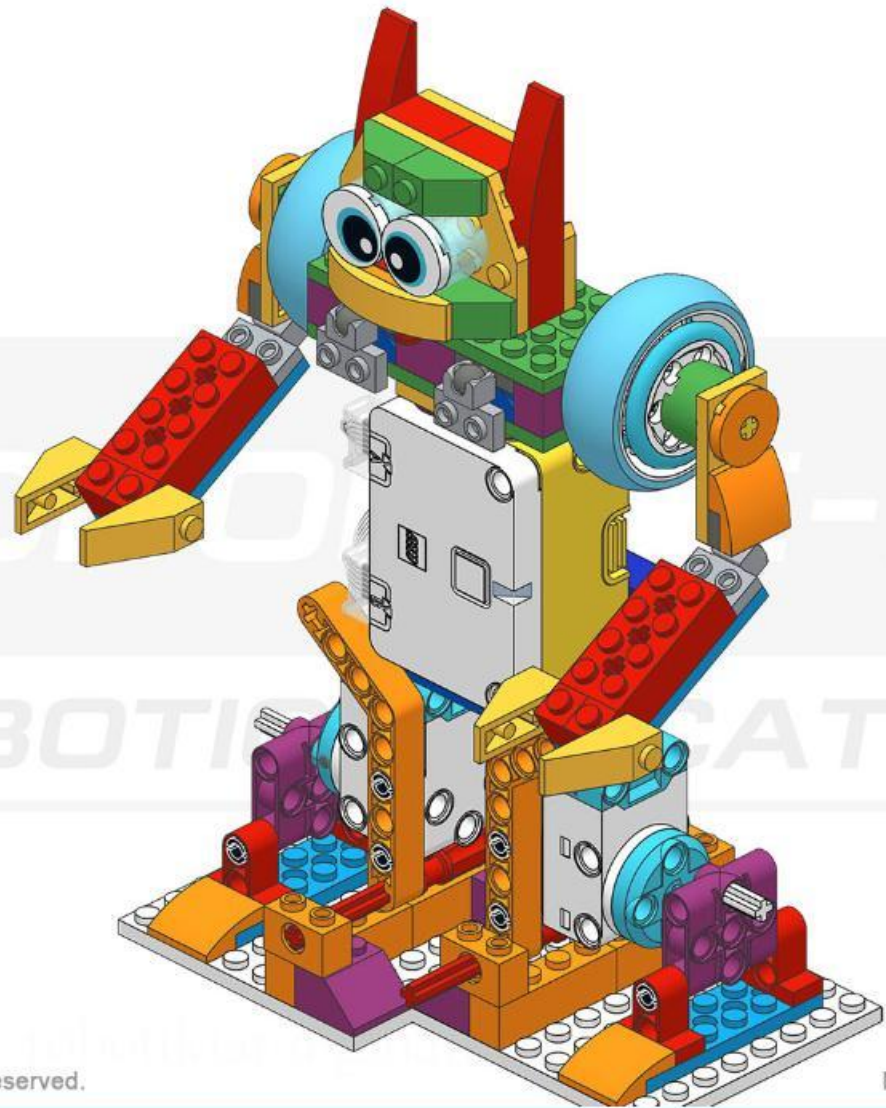

29/34

0

98



©2021 roboriseit.com. All rights reserved.

Model by Ignat Khlebnikov

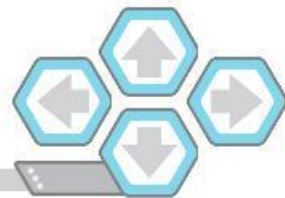

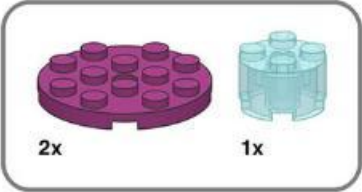
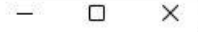

77

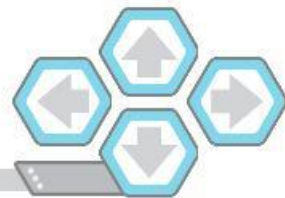
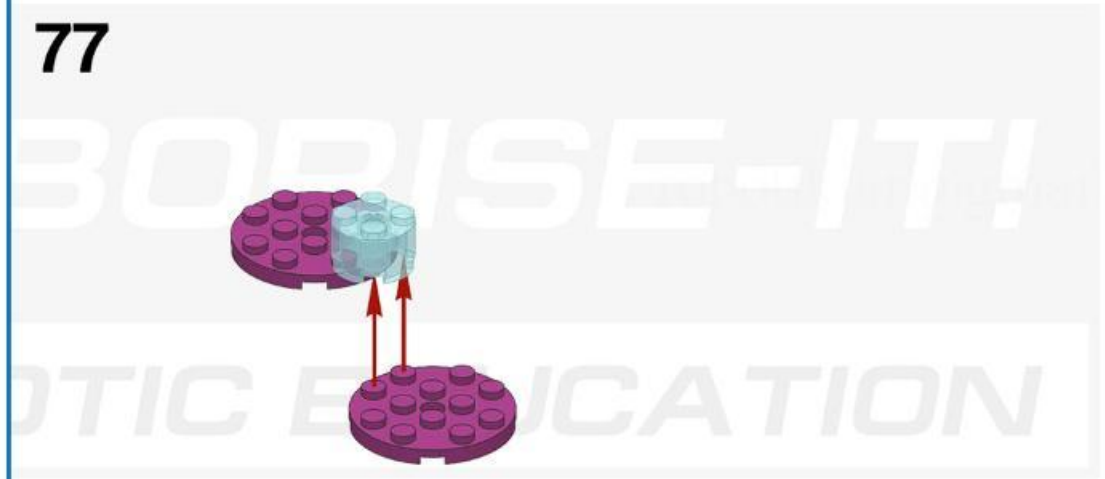

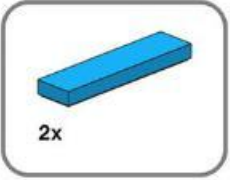

78

ROBORISE-IT!
ROBOTIC EDUCATION

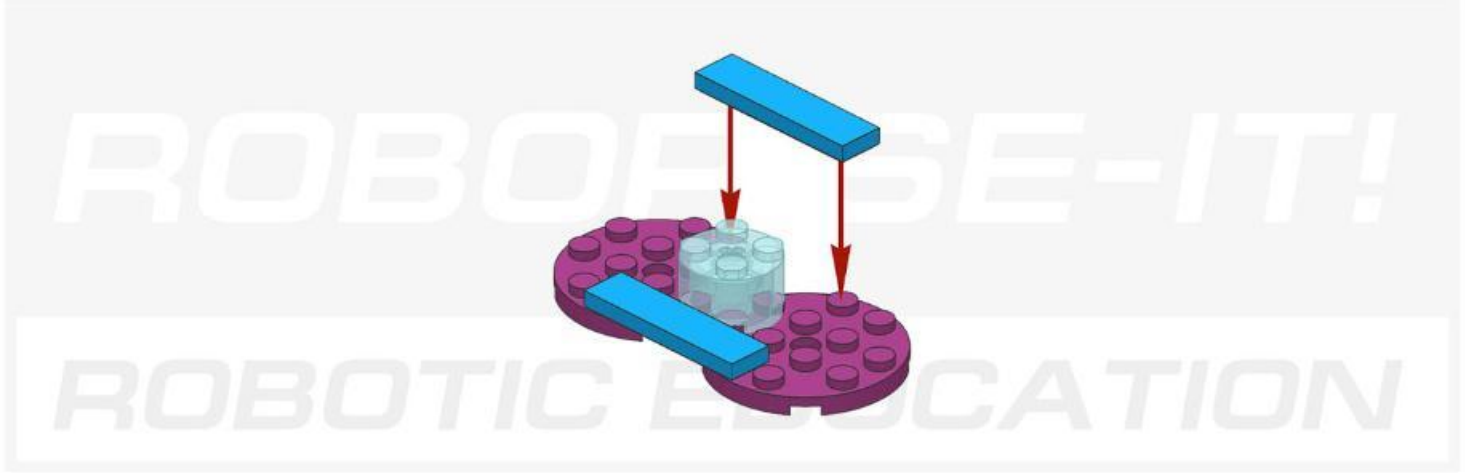

31/34

0

100



©2021 roboriseit.com. All rights reserved.

Model by Ignat Khlebnikov

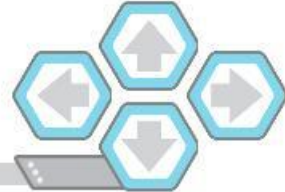

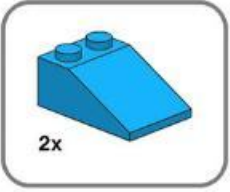

79

ROBORISE-IT!
ROBOTIC EDUCATION

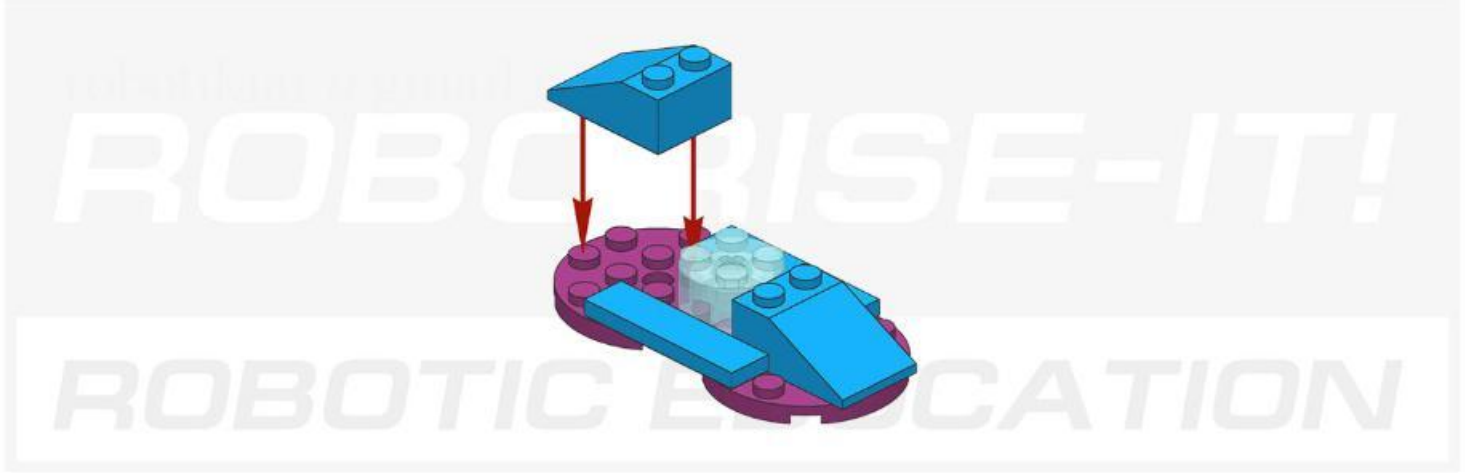

32/34

0

101



©2021 roboriseit.com. All rights reserved.

Model by Ignat Khliebnikov

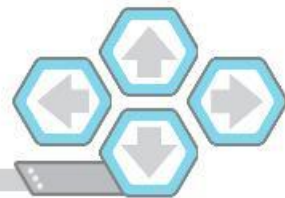

roboriseit.com

ROBORISE-IT!



ROBOTIC EDUCATION





81

ROBORISE-IT!
ROBOTIC EDUCATION



ROBORISE-IT!
ROBOTIC EDUCATION

34/34

0

103



©2021 roboriseit.com. All rights reserved.

Model by Ignat Khlebnikov

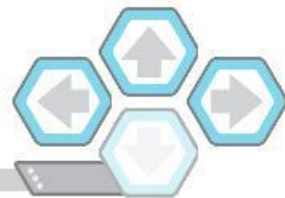



Task 3*. Program 2

Algorithm

Program

If you have enough time, you can create a block for moving the robot forward yourself based on the program you wrote to move the robot forward:

```
define 0-Walk distance cm  
  set Center Button light to   
  A go shortest path to position 90  
  B go shortest path to position 90  
  set movement speed to 50 %  
  move ↑ for distance cm
```

ROBORISE-IT!
ROBOTIC EDUCATION

